

# PETERSEN ALUMINUM CORPORATION TEST REPORT

**SCOPE OF WORK**

TAS 125 UPLIFT RESISTANCE TESTING OF 0.032" X 18" WIDE ALUMINUM TITE LOC PLUS MECHANICAL SEAM ROOF SYSTEM OVER 5/8" PLYWOOD

**REPORT NUMBER**

M5239.02-450-18 R0

**TEST DATE(S)**

08/08/12 – 12/04/20

**ISSUE DATE**

07/29/21

**PAGES**

17

**DOCUMENT CONTROL NUMBER**

RT-R-AMER-Test-2958 (03/11/20)

© 2017 INTERTEK

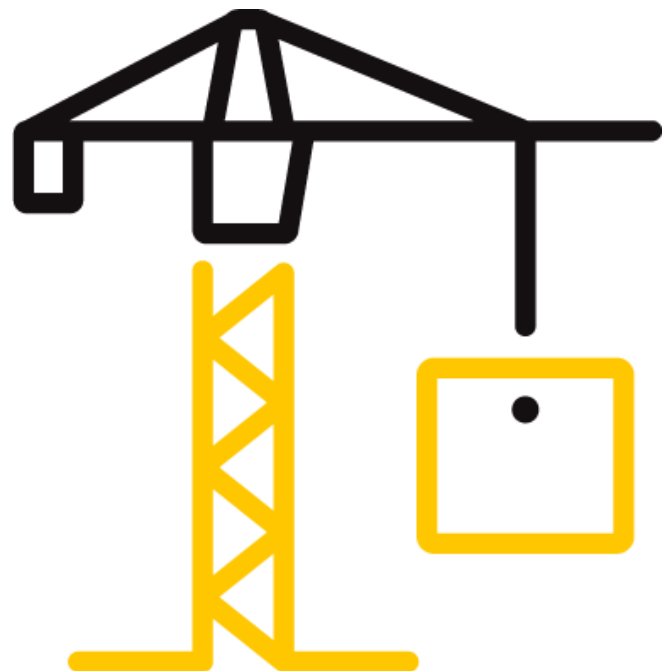

## TEST REPORT FOR PETERSEN ALUMINUM CORPORATION

Report No.: M5239.02-450-18 R0

Date: 07/29/21

### REPORT ISSUED TO

#### PETERSEN ALUMINUM CORPORATION

102 Northpoint Parkway

Acworth, Georgia 30102

### SECTION 1

#### SCOPE

Architectural Testing, Inc. (an Intertek company), dba Intertek Building & Construction (B&C) was contracted by Petersen Aluminum Corporation to perform testing in accordance with TAS 125, *Standard Requirements for Metal Roofing Systems*, on their 0.032" x 18" Wide Aluminum Tite Loc Plus Mechanical Seam Roof Panels. Results obtained are tested values and were secured by using the designated test method(s). Testing was conducted at Intertek B&C test facility in West Palm Beach, FL.

This report does not constitute certification of this product nor an opinion or endorsement by this laboratory. Intertek B&C will service this report for the entire test record retention period. The test record retention period ends four years after the test date. Test records, such as detailed drawings, datasheets, representative samples of test specimens, or other pertinent project documentation, will be retained for the entire test record retention period.

Unless differently required, Intertek reports apply the "Simple Acceptance" rule, also called "Shared Risk approach," of ILAC-G8:09/2019, Guidelines on Decision Rules and Statements of Conformity.

For INTERTEK B&C:

<b>COMPLETED BY:</b>	Melissa Nuttall	<b>REVIEWED BY:</b>	Vinu J. Abraham, P.E.
<b>TITLE:</b>	Technician Team Leader – Product Testing	<b>TITLE:</b>	Vice President – Products
<b>SIGNATURE:</b>		<b>SIGNATURE:</b>	
<b>DATE:</b>	07/29/21	<b>DATE:</b>	07/29/21

MMN:sar

This report is for the exclusive use of Intertek's Client and is provided pursuant to the agreement between Intertek and its Client. Intertek's responsibility and liability are limited to the terms and conditions of the agreement. Intertek assumes no liability to any party, other than to the Client in accordance with the agreement, for any loss, expense or damage occasioned by the use of this report. Only the Client is authorized to permit copying or distribution of this report and then only in its entirety. Any use of the Intertek name or one of its marks for the sale or advertisement of the tested material, product or service must first be approved in writing by Intertek. The observations and test results in this report are relevant only to the sample(s) tested. This report by itself does not imply that the material, product, or service is or has ever been under an Intertek certification program.

## TEST REPORT FOR PETERSEN ALUMINUM CORPORATION

Report No.: M5239.02-450-18 R0

Date: 07/29/21

### SECTION 2

#### SUMMARY OF TEST RESULTS

**Product Type:** Metal Roof Panels

**Series/Model:** Tite Loc Plus

**Specimen 1 – Ultimate Test Load Achieved:** -127.0psf

**Specimen 2 – Ultimate Test Load Achieved:** -348.5psf

### SECTION 3

#### TEST METHOD(S)

The specimens were evaluated in general accordance with the following:

**TAS 125-03**, *Standard Requirements for Metal Roofing Systems* (Only 2 field specimens tested)

### SECTION 4

#### MATERIAL SOURCE/INSTALLATION

Test specimens were provided by the client. Representative samples of the test specimen(s) will be retained by Intertek B&C for a minimum of four years from the test completion date.

Installation of the tested product was performed by representatives of the client.

### SECTION 5

#### EQUIPMENT

**Cycling and Static Load Mechanism:** Computer controlled centrifugal blowers with electronic pressure measuring device.

**Deflection Measuring Device:** Linear Transducers

### SECTION 6

#### LIST OF OFFICIAL OBSERVERS

NAME	COMPANY
Veron Wickham	Intertek B&C
Melissa Nuttall	Intertek B&C

**TEST REPORT FOR PETERSEN ALUMINUM CORPORATION**

Report No.: M5239.02-450-18 R0

Date: 07/29/21

**SECTION 7**

**TEST PROCEDURE**

This test evaluates the comparative resistance of roof assemblies to positive and negative pressures by simulating the effects of wind gusts by use of oscillating exterior pressure and constant interior pressures. Two assemblies were tested per TAS 125 at each class rating. (Reference Chart No. 1 for test pressures and load durations.) The measurements were taken via linear transducers for specimen 1. For Specimen 2, the measurements were taken via a transit and steel scales mounted to the roof panels. The initial measurements were "zero" point, not actual deflection. Actual deflection is Phase 1, 2, 3 maximum, 4 or 5 reading less the initial (0.0 psf) reading. The final reading was taken after the completion of an entire class had been completed and became the initial reading for the following class test.

TEST PHASE	DURATION minutes	NEGATIVE PRESSURE		POSITIVE PRESSURE	
		POUNDS PER SQUARE FOOT psf (kPa)	INCHES OF WATER inches (mm)	POUNDS PER SQUARE FOOT psf (kPa)	INCHES OF WATER inches (mm)
<b>Class 30</b>					
1	5	16.2 (0.79)	3.1 (79)	0.0 (0.00)	0.0 (0)
2	5	16.2 (0.79)	3.1 (79)	13.8 (0.66)	2.7 (69)
3	60	8.1 - 27.7 (0.39 - 1.33)	1.5 - 5.3 (38 - 135)	13.8 (0.66)	2.7 (69)
4	5	24.2 (1.16)	4.7 (119)	0.0 (0.00)	0.0 (0)
5	5	24.2 (1.16)	4.7 (119)	20.8 (1.00)	4.0 (102)
<b>Class 60</b>					
1	5	32.3 (1.55)	6.2 (157)	0.0 (0.00)	0.0 (0)
2	5	32.3 (1.55)	6.2 (157)	27.7 (1.33)	5.3 (135)
3	60	16.2 - 55.4 (0.79 - 2.66)	3.1 - 10.7 (79 - 272)	27.7 (1.33)	5.3 (135)
4	5	40.4 (1.94)	7.8 (198)	0.0 (0.00)	0.0 (0)
5	5	40.4 (1.94)	7.8 (198)	34.6 (1.66)	6.7 (170)
<b>Class 90 (maximum combined uplift pressure of 105 psf)</b>					
1	5	48.5 (2.33)	9.3 (236)	0.0 (0.00)	0.0 (0)
2	5	48.5 (2.33)	9.3 (236)	41.5 (1.99)	8.0 (203)
3	60	24.2 - 48.5 (1.16 - 2.33)	4.7 - 9.3 (119 - 236)	41.5 (1.99)	8.0 (203)
4	5	56.5 (2.71)	10.9 (277)	0.0 (0.00)	0.0 (0)
5	5	56.5 (2.71)	10.9 (277)	48.5 (2.33)	9.3 (236)

**Chart No. 1  
TAS 125 Load Table Test Pressures**

## TEST REPORT FOR PETERSEN ALUMINUM CORPORATION

Report No.: M5239.02-450-18 R0

Date: 07/29/21

### SECTION 8

#### TEST SPECIMEN DESCRIPTION

**Product Type:** Metal Roof Panels

**Series/Model:** Tite Loc Plus

#### Product Size(s):

##### All Specimens

OVERALL AREA:	WIDTH		HEIGHT	
	millimeters	inches	millimeters	inches
9.3 m <sup>2</sup> (100.0 ft <sup>2</sup> )				
Overall Size	3048	120	3048	120
Panel Coverage	457	18	3048	120

*The following description applies to all specimens.*

#### Test Deck Construction:

The 10' 0" wide by 10' 0" long by 1' 3" deep test frame was fabricated from C15 by 33.9 steel channels. The test frame utilized joists constructed from Southern Yellow Pine 2 x 12 lumber located on two sides of the test frame and spaced 24" on center. The joists were secured to the test frame using two 1/2" x 3" long bolts with washers and nuts through an 8" long, 2" by 4" by 1/8" steel angle with pre-drilled fastener locations. The steel angles were welded to the test frame 24" on center. Southern Yellow Pine 2 x 12 lumber was utilized as cross members located at mid-span. 5/8" (19/32" min) thick 5-ply plywood sheathing was utilized on the top of the test deck. The plywood was secured using 8d coated ring shank nails spaced 6" on center.

## TEST REPORT FOR PETERSEN ALUMINUM CORPORATION

Report No.: M5239.02-450-18 R0

Date: 07/29/21

### Specimens #1 Roof System:

COMPONENTS	DETAILS	ATTACHMENT METHOD
30# Asphalt saturated organic felt paper	A single layer was used with a 2" overlap between adjacent sheets.	0.120" x 1-1/4" galvanized annular ring shank roofing nails with 32 Ga tin caps spaced 6" on center at the perimeter and overlaps, with two intermediate rows spaced 12" on center.
Vapor and moisture barrier	A single layer of QUIK-Stick HT membrane was applied over the felt paper.	Self-adhered to felt paper.
Fire barrier	A single layer of VersaShield was used with a 2" overlap between adjacent sheets.	Laid loosely over the membrane
Clip assembly (base)	The 1.820" x 0.143" x 2.500" (long) clip base was constructed from 18 Ga. steel.	Each panel's sliding clip consisted of a "base" and a "tab" that were each fabricated from two different thickness of steel. Each clip "base" had two holes capable of accommodating 1/4" pancake head screws.
Clip assembly (tab)	The 1.835" x 2.125" x 4.313" (long) clip tab was constructed from 22 Ga. Steel.	
Roof Panel	The panels were constructed from 0.032" aluminum and had an 18" coverage width. Six full panels and two partial panels were tested.	Each roof panel was mechanically attached to the plywood substrate along the male leg using a series of individual sliding clips located at a 36" on center. Each individual sliding clip was hooked over the male leg and secured to the plywood using two, #10 x 1-1/2" pancake head screws. Once the clips were secured in place, then the female leg of the adjacent roof panel was fit over the clips and male leg of the panel and the legs were then mechanically seamed 180 degrees. Sealant was not used in the seams. The perimeter was secured with the same screws spaced 2" on center.

## TEST REPORT FOR PETERSEN ALUMINUM CORPORATION

Report No.: M5239.02-450-18 R0

Date: 07/29/21

### Specimens #2 Roof System:

COMPONENTS	DETAILS	ATTACHMENT METHOD
30# Asphalt saturated organic felt paper	A single layer was used with a 2" overlap between adjacent sheets.	0.120" x 1-1/4" galvanized annular ring shank roofing nails with 32 Ga tin caps spaced 6" on center at the perimeter and overlaps, with two intermediate rows spaced 12" on center.
Vapor and moisture barrier	A single layer of QUIK-Stick HT membrane was applied over the felt paper.	Self-adhered to felt paper.
Fire barrier	A single layer of VersaShield was used with a 2" overlap between adjacent sheets.	Laid loosely over the membrane
Clip assembly (base)	The 1.820" x 0.143" x 2.500" (long) clip base was constructed from 18 Ga. steel.	Each panel's sliding clip consisted of a "base" and a "tab" that were each fabricated from two different thickness of steel. Each clip "base" had two holes capable of accommodating 1/4" pancake head screws.
Clip assembly (tab)	The 1.835" x 2.125" x 4.313" (long) clip tab was constructed from 22 Ga. Steel.	
Roof Panel	The panels were constructed from 0.032" aluminum and had an 18" coverage width. Six full panels and two partial panels were tested.	Each roof panel was mechanically attached to the plywood substrate along the male leg using a series of individual sliding clips located at a 6" on center. Each individual sliding clip was hooked over the male leg and secured to the plywood using two, #10 x 1-1/2" pancake head screws. Once the clips were secured in place, then the female leg of the adjacent roof panel was fit over the clips and male leg of the panel and the legs were then mechanically seamed 180 degrees. Sealant was not used in the seams. The perimeter was secured with the same screws spaced 1" on center.

## TEST REPORT FOR PETERSEN ALUMINUM CORPORATION

Report No.: M5239.02-450-18 R0

Date: 07/29/21

### SECTION 9

#### TEST RESULTS

The results are tabulated as follows.

##### Test Specimen #1

TEST TITLE	OBSERVATIONS	DEFLECTION MEASUREMENTS	RESULTS
Class 30, Phases 1-5	No visible damage to system	Reference Table No. 1	PASSED
Class 60, Phases 1-5	No visible damage to system	Reference Table No. 1	PASSED
Class 90, Phases 1-5	No visible damage to system	Reference Table No. 1	PASSED
Supplemental Loads -112 psf to -127 psf	No visible damage to system	Reference Table No. 2	PASSED
Supplemental Loads -142 psf	Screws pulled out of plywood	Reference Table No. 2	FAILED

##### Test Specimen #2

TEST TITLE	OBSERVATIONS	DEFLECTION MEASUREMENTS	RESULTS
Class 30, Phases 1-5	No visible damage to system	Reference Table No. 3	PASSED
Class 60, Phases 1-5	No visible damage to system	Reference Table No. 3	PASSED
Class 90, Phases 1-5	No visible damage to system	Reference Table No. 3	PASSED
Supplemental Loads -78.5psf to -348.5psf	No visible damage to system	N/A	PASSED
Supplemental Loads -363.5 psf	2x12 split	N/A	FAILED

#### Notes:

*Reference Chart No. 1 for test pressures and load durations.*

*Reference Sketch No. 1 for location of deflection measurement devices.*

*A loose fitting, pleated 4-mil plastic film was utilized to assist in obtaining uniform pressure on the roof system. The plastic film was located between the moisture barrier and the roof panels to facilitate testing. In our opinion, this did not influence test results.*

*Supplemental loads per UL 1897 increased in increments of 15 psf and started at -112 psf total load for Specimen 1 and 78.5 psf for Specimen 2.*





Total Quality. Assured.

2658 Electronics Way  
West Palm Beach, Florida 33407

Telephone: 561-881-0020  
Facsimile: 717-764-4129  
[www.intertek.com/building](http://www.intertek.com/building)

## TEST REPORT FOR PETERSEN ALUMINUM CORPORATION

Report No.: M5239.02-450-18 R0

Date: 07/29/21

### SECTION 10

#### CONCLUSION

The product tested per TAS 125 achieved:

Specimen 1 – Ultimate Test Load: -127.0 psf

Specimen 2 – Ultimate Test Load: -348.5 psf

## TEST REPORT FOR PETERSEN ALUMINUM CORPORATION

Report No.: M5239.02-450-18 R0

Date: 07/29/21

### SECTION 11 SKETCH(ES)

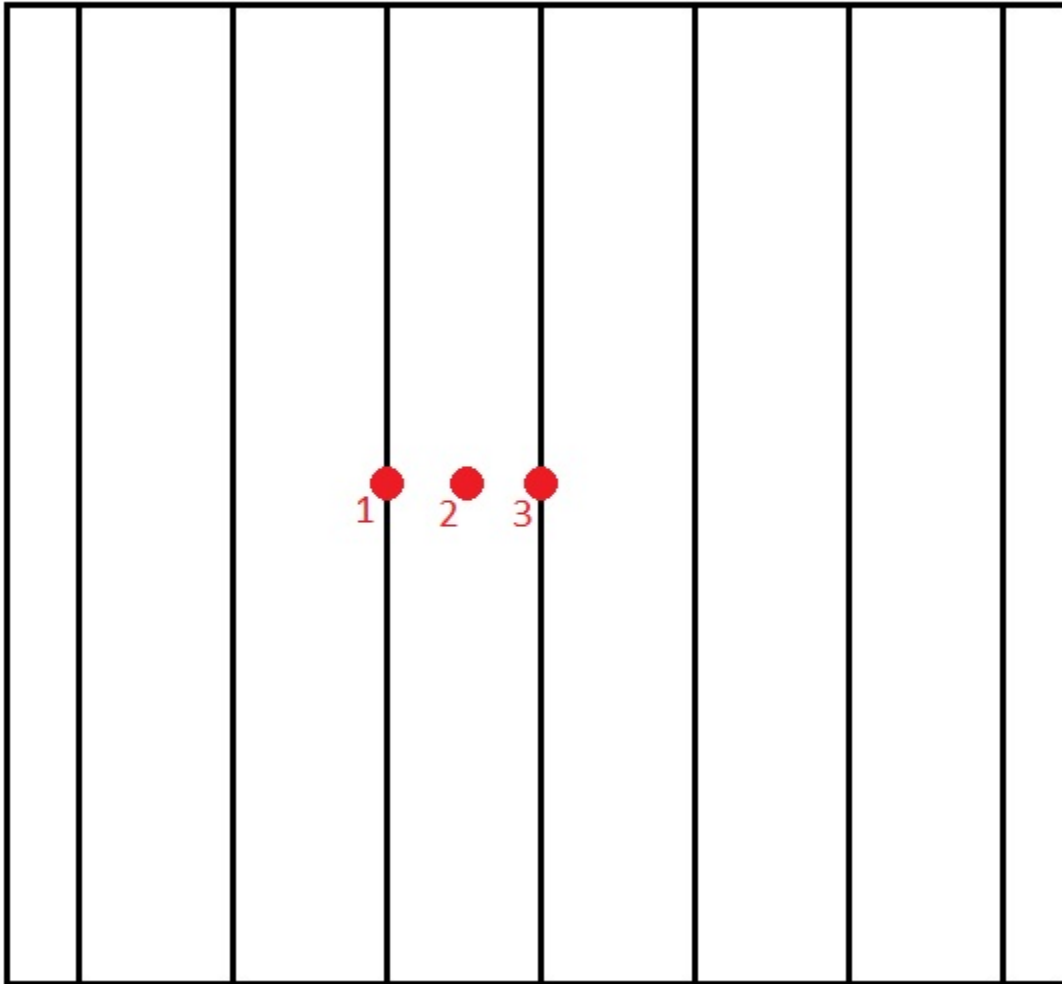

Sketch No. 1  
Deflection Measurement Device Locations

**TEST REPORT FOR PETERSEN ALUMINUM CORPORATION**

Report No.: M5239.02-450-18 R0

Date: 07/29/21

**SECTION 12**

**DEFLECTION TABLES**

CLASS	PHASE	DEFLECTION MEASUREMENTS (inches)		
		INDICATOR		
		#1	#2	#3
30	1	0.15	1.14	0.20
	2	0.24	1.46	0.31
	3 Minimum	0.25	1.39	0.30
	3 Maximum	0.29	1.61	0.37
	4	0.24	1.42	0.31
	5	0.34	1.81	0.47
	Final (0.0 psf)	0.09	0.18	0.07
60	1	0.31	1.67	0.40
	2	0.41	2.04	0.58
	3 Minimum	0.49	2.10	0.63
	3 Maximum	0.57	2.28	0.78
	4	0.47	2.00	0.61
	5	0.59	2.40	0.81
	Final (0.0 psf)	0.16	0.03	0.16
90	1	0.51	2.16	0.67
	2	0.66	2.56	0.91
	3 Minimum	0.68	2.51	0.86
	3 Maximum	0.71	2.62	0.95
	4	0.66	2.39	0.85
	5	0.91	2.93	1.20
	Final (0.0 psf)	0.46	0.92	0.48

**Table No. 1**  
**Deflection Measurements – Test Specimen #1**

**TEST REPORT FOR PETERSEN ALUMINUM CORPORATION**

Report No.: M5239.02-450-18 R0

Date: 07/29/21

VACUUM (psf)	UPLIFT (psf)	LOAD (psf)	SUPPLEMENTAL DEFLECTION MEASUREMENTS (inches)		
			INDICATOR		
			#1	#2	#3
-63.5	-48.5	-112.0	1.07	3.12	1.44
-78.5	-48.5	-127.0	1.27	3.43	1.79
-93.5	-48.5	-142.0	Failed		

**Table No. 2**  
**Supplemental Deflection Measurements – Test Specimen #1**

**TEST REPORT FOR PETERSEN ALUMINUM CORPORATION**

Report No.: M5239.02-450-18 R0

Date: 07/29/21

CLASS	PHASE	DEFLECTION MEASUREMENTS (inches)		
		INDICATOR		
		#1	#2	#3
30	Initial (0.0 psf)	6.3	6.2	6.1
	1	6.4	6.5	6.2
	2	6.5	6.9	6.3
	3 Maximum	6.5	7.0	6.3
	4	6.5	7.1	6.3
	5	6.6	7.2	6.4
	Final (0.0 psf)	6.4	6.6	6.2
60	1	6.6	7.3	6.4
	2	6.6	7.4	6.5
	3 Maximum	6.7	7.4	6.5
	4	6.6	7.2	6.4
	5	6.7	7.5	6.5
	Final (0.0 psf)	6.4	6.7	6.2
90	1	6.6	7.4	6.4
	2	6.7	7.6	6.5
	3 Maximum	6.7	7.4	6.5
	4	6.7	7.5	6.5
	5	6.8	7.7	6.6
	Final (0.0 psf)	6.5	6.8	6.2

**Table No. 3**  
**Deflection Measurements – Test Specimen #2**

**TEST REPORT FOR PETERSEN ALUMINUM CORPORATION**

Report No.: M5239.02-450-18 R0

Date: 07/29/21

**SECTION 13**

**LOAD TABLE**

**Load Table: 0.032" x 18" Wide Aluminum Tite Loc Plus Panel Over 5/8" Plywood**

Clip Spacing, L	Clip Spacing, L	Test Result	Allowable Design Pressure with Safety Factor of 1.65	Allowable Design Pressure with Safety Factor of 2.00
0'-6"	6"	<b>-348.5 psf</b>	-211.2 psf	-174.2 psf
1'-0"	12"		-193.0 psf	-159.2 psf
1'-6"	18"		-174.8 psf	-144.2 psf
2'-0"	24"	<b>-258.5 psf</b>	-156.7 psf	-129.2 psf
2'-6"	30"		-116.8 psf	-96.4 psf
3'-0"	36"	<b>-127.0 psf</b>	-77.0 psf	-63.5 psf

**General Notes:**

*Intermediate values based on linear interpolation from tested values.*

*Actual testing was conducted at 0'-6", 2'-0" and 3'-0" clip spacing.*

Vinu Abraham  
Vice President - Products  
July 29, 2021

## TEST REPORT FOR PETERSEN ALUMINUM CORPORATION

Report No.: M5239.02-450-18 R0

Date: 07/29/21

### SECTION 14 DRAWINGS

The test specimen drawings have been reviewed by Intertek B&C and are representative of the test specimen(s) reported herein. Test specimen construction was verified by Intertek B&C per the drawings included in this report. Any deviations are documented herein or on the drawings.

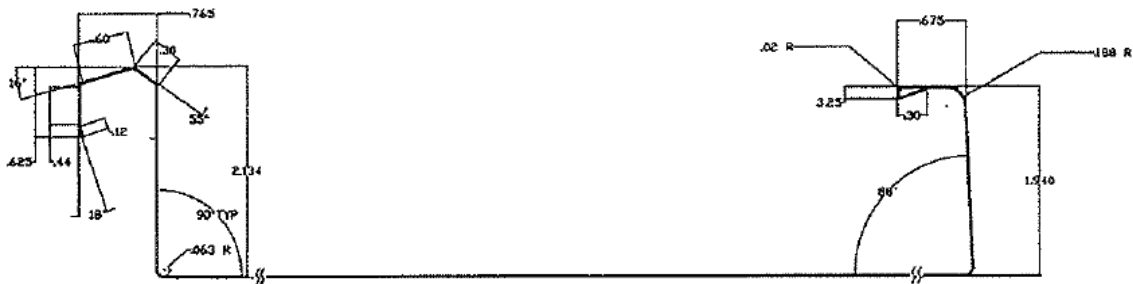

TITE LOC PLUS  
0.032" Aluminum  
18" COVERAGE  
ON 5/8" PLYWOOD

**Drawing No. 1  
Panel Profile**

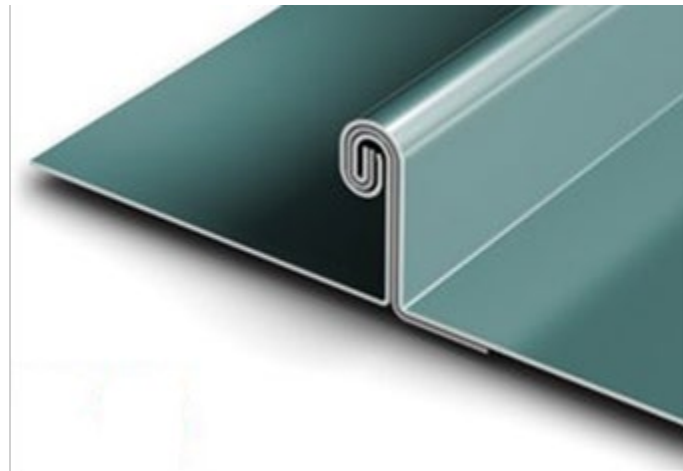

**Drawing No. 2  
Seam Detail**

## TEST REPORT FOR PETERSEN ALUMINUM CORPORATION

Report No.: M5239.02-450-18 R0

Date: 07/29/21

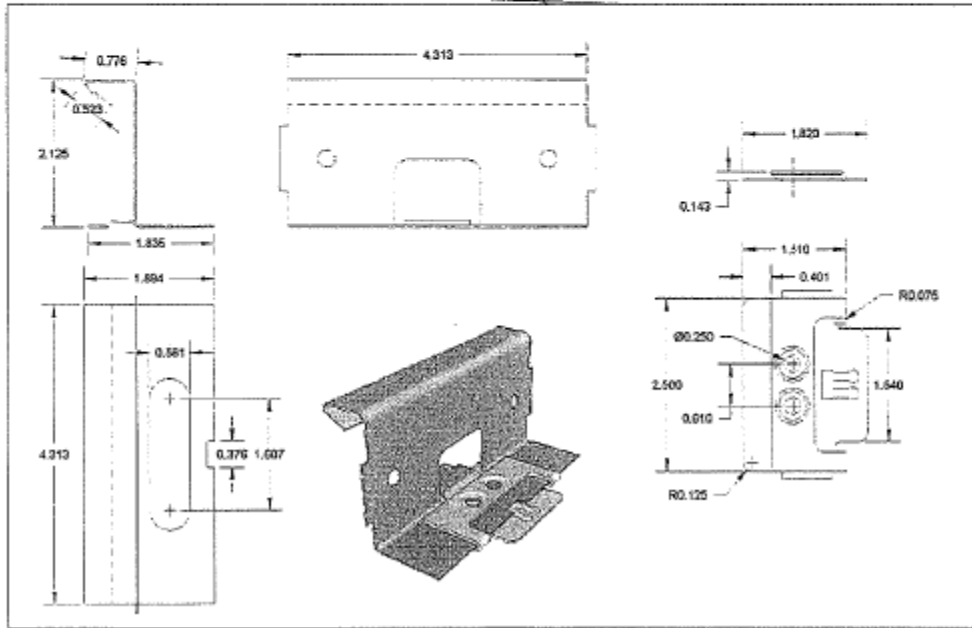
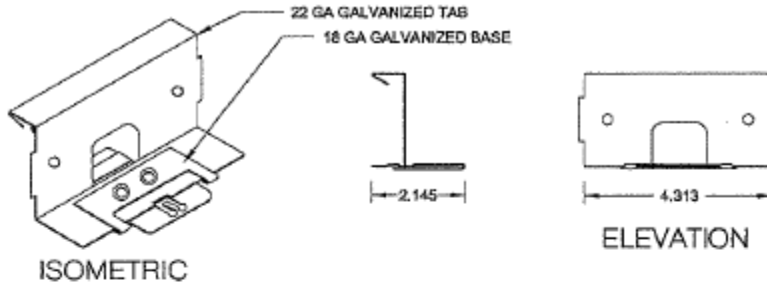

**Drawing No. 3**  
**Clip Dimensions**





Total Quality. Assured.

2658 Electronics Way  
West Palm Beach, Florida 33407

Telephone: 561-881-0020  
Facsimile: 717-764-4129  
[www.intertek.com/building](http://www.intertek.com/building)

## TEST REPORT FOR PETERSEN ALUMINUM CORPORATION

Report No.: M5239.02-450-18 R0

Date: 07/29/21

### SECTION 15

#### REVISION LOG

REVISION #	DATE	PAGES	REVISION
0	07/29/21	N/A	Original Report Issue